

Features

- ✧ Twin LED for 360° view.
- ✧ Remote indicator output available.
- ✧ Complies with EN 54-7 standard.

Description

C-9102 Conventional Photoelectric Smoke Detector is non-addressable. Used together with end of line unit, it can connect with compatible control panels to process detection signals. It shows fire alarm by LED indicators and transmits the fire signal to the control panel. Using infrared scattering technology, the smoke density can be detected. The detector receives very weak infrared light under normal smokeless condition. If smoke particles enter the chamber, the received light signal will increase by scattering. When smoke density reaches a pre-set level, the detector will alarm out. In order to reduce interference and power consumption, the emitting circuit works in pulse mode to prolong the life of IR LED.

Connection and Cabling

Fig.1 shows the detector bottom and Fig. 2 the base.

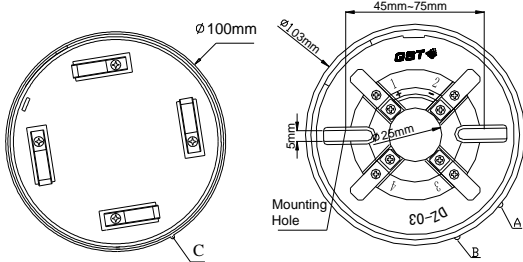

Fig. 1

Fig. 2

There are four terminals with numbers on the base.

- 1: Detection zone positive IN
 - 2: Detection zone positive OUT
 - 3: Detection zone negative IN and OUT
-
- 2: Positive terminal of remote indicator
 - 4: Negative terminal of remote indicator

Recommended Cabling

1.0mm² or above fire cable is recommended but subject to local codes.

Installation

A fixed installation direction is ensured by the location elements on the detector and the base. Fix the base with two tapping screws, and then align mark C on the detector with A on the base, rotate the detector to align mark C with mark B (Refer to Fig. 1 and 2 for the position of the marks), the detector will be fitted to the base.

Note: The detector shall be horizontally installed. If it has to be installed on an inclined plane, the inclination angle shall not be over 45°.



Fig. 3 shows the installation of the detector.

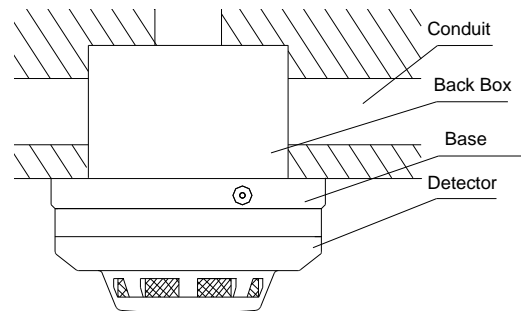

Fig. 3

Application

Warning: The detector should be connected with a fire alarm control panel or other devices with current limit function. Otherwise the detector may be damaged by heavy alarm current.

✧ When the detector is connected with a compatible fire alarm control panel in series, with a P-9907 active end of line unit connected to the end of loop, a 1N5819 Diode should be connected on the detector base.

- Used as the detector base, the AEOL is to install a conventional detector on it. The system connection is shown in Fig. 4.

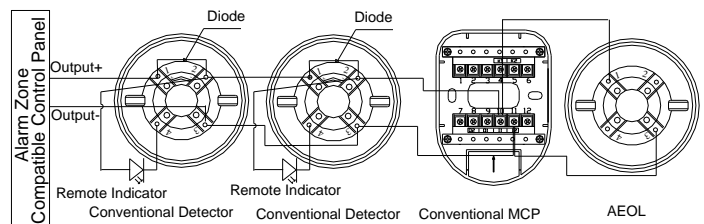

Fig. 4

- When the AEOL is not used as the detector base, a cover should be put. The system connection is shown in Fig. 5.

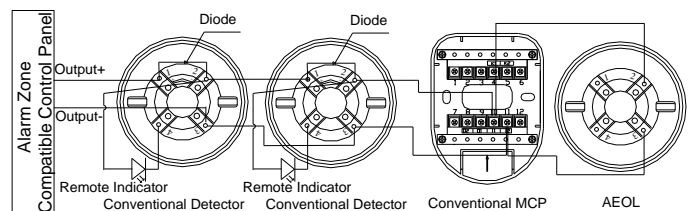

Fig. 5

✧ When the detector is connected with a compatible fire alarm control panel, with an end of line resistor connected to the end of loop, there should be no diode connected on the base. The system connection is shown in Fig. 6.

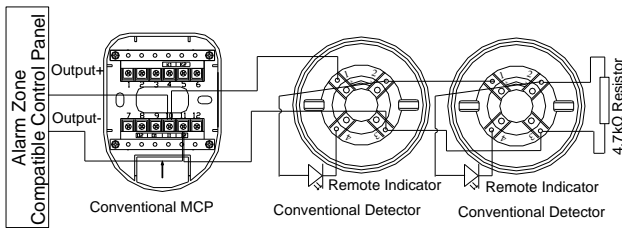

Fig. 6

Maximum 15 detectors can be connected in one zone. Cooperating with end of line device, the compatible panel can monitor the cable for open circuit and short circuit. Panel will report if any detector is removed. With Active End of Line unit (AEOL), the functioning of other device will not be affected by the detector removal.

Maintenance

1. The detector should be installed just before commissioning and kept well before installation, taken corresponding measures for dust-proof, damp-proof and corrosion-proof.
2. The dust-proof cover should not be removed until the project plunged into usage. Otherwise it may not report alarm properly.
3. Clean the detectors regularly, at least once a year to ensure normal operation of the system.
4. Maintenance should be carried out for false alarm detectors, either clean or replace the chamber if necessary. Before cleaning, notify the proper authorities that the system is under maintenance and will temporarily be out of service. Disable the automatic controls relating to the zone or system under maintenance to avoid unwanted actions.

Steps for chamber cleaning:

- a) Open the top cover of detector.
 - b) Draw out the chamber slightly shaking by hand.
 - c) Clean the internal of the chamber by alcohol cotton or other clean liquid swab with tweezers. Make sure not to leave any fiber in the chamber.
 - d) Put back the chamber and the top cover.
5. The detector should be tested after re-installed to ensure normal operation.
 6. Fire simulation test should be done to the detector at least every 6 months.

Specification

Operating Voltage	24VDC (12VDC~28VDC)
Standby Current	≤60μA
Alarm Current	10mA≤I≤30mA
Indicators	Red. Quiet in normal condition. Illuminates steadily in alarm.
Remote Indicator Output	Directly connecting with LED (built-in 2kΩ resistor in series). Quiet in normal condition. Illuminates steadily in alarm.
Maximum Ripple Voltage	4V (peak-to-peak)
Alarm Clear	Instantaneous Power-off (5s Max., 2.5VDC Max.)
Power-up Time	≤10s
Max. Wind Speed	7.6m/s (1500fpm)
Wiring	Polarized 2-core for detection zone cable. Polarized 2-core for remote indicator.
Ambient temperature	-10°C~+50°C
Relative Humidity	≤95%, non condensing
Ingress Protection Rate	IP23
Material and Color of Enclosure	ABS, white (RAL 9016)
Dimensions	Diameter: 100mm Height: 56mm (with base)
Mounting Hole Distance	45mm~75mm
Weight	About 120g

Accessories and Tools

Model	Name	Remarks
P-9907	Active End of Line Unit	Order separately
DZ-03	Base	Order separately

Limited Warranty

GST warrants that the product will be free of charge for repairing or replacing from defects in design, materials and workmanship during the warranty period. This warranty does not cover any product that is found to have been improperly installed or used in any way not in accordance with the instructions supplied with the product. Anybody, including the agents, distributors or employees, is not in the position to amend the contents of this warranty. Please contact your local distributor for products not covered by this warranty.

This Data Sheet is subject to change without notice. Please contact GST for more information or questions.

Gulf Security Technology Co., Ltd.

No. 80, Changjiang East Road, QETDZ, Qinhuangdao, Hebei, P. R. China 066004

Tel: +86 (0) 335 8502434 Fax: +86 (0) 335 8502532

service.gst@fs.utc.com www.gst.com.cn